

Supporting materials for school visits

Contents

- Activity sheets for the Roman galleries in the Castle Museum
- Helpers' Guidelines
- Orientation map of the Castle Museum
- Map of Colchester
- Evaluation form

Please print these sheets and photocopy them for your group.

'If you have already booked, you should have received a booking form, timetable and information sheet. If you have not received these, please contact the information and Bookings Officer on **01206 282937**.'

**YOUR VISIT IS NOT BOOKED
UNLESS YOU HAVE SPOKEN
TO OUR INFORMATION AND
BOOKINGS OFFICER, ON
01206 282937
TO DISCUSS AND BOOK
YOUR VISIT.**



ACTIVITY 1

THE EVIDENCE

1 Find the big floor leaning against the wall.

Is it the same pattern all over?

Draw the section that is different from the rest.

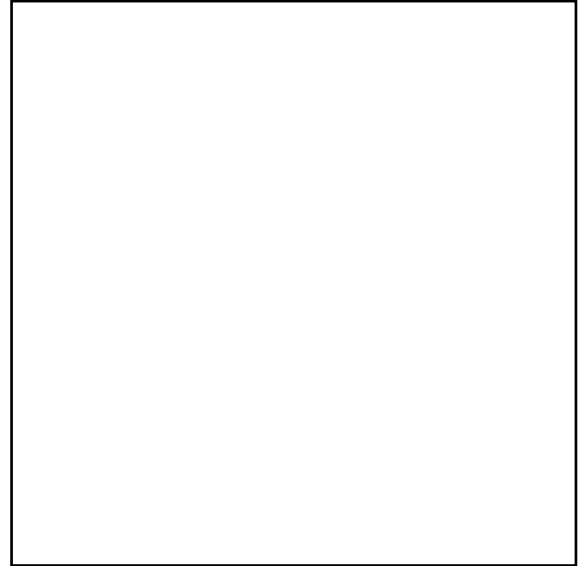

2 Look at the objects on this tray.
Draw a ring round the objects you find that will survive for 2,000 years underground.

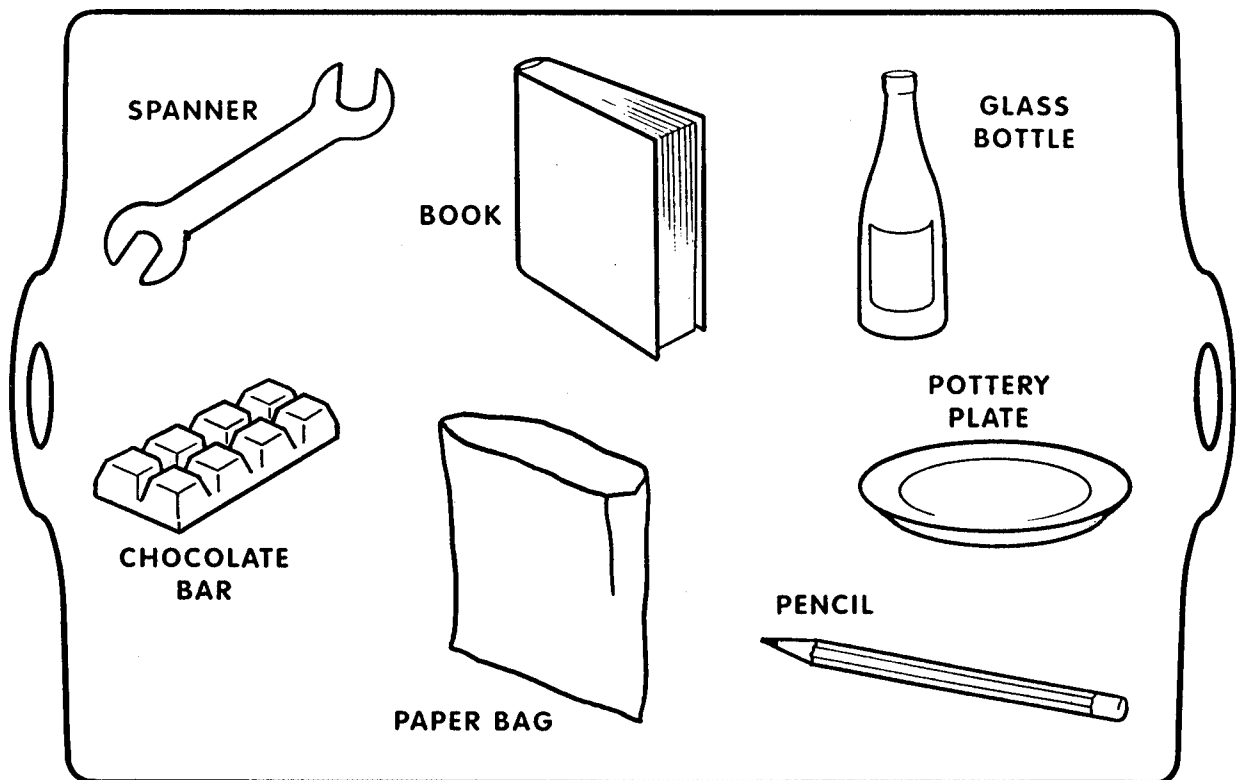

ACTIVITY 1: The Evidence

3 Find this Bronze Age pot used by Celts.

Draw the pattern on the pot.

Tick how it was made:

- 1) in a mould
- 2) by hand
- 3) on a wheel

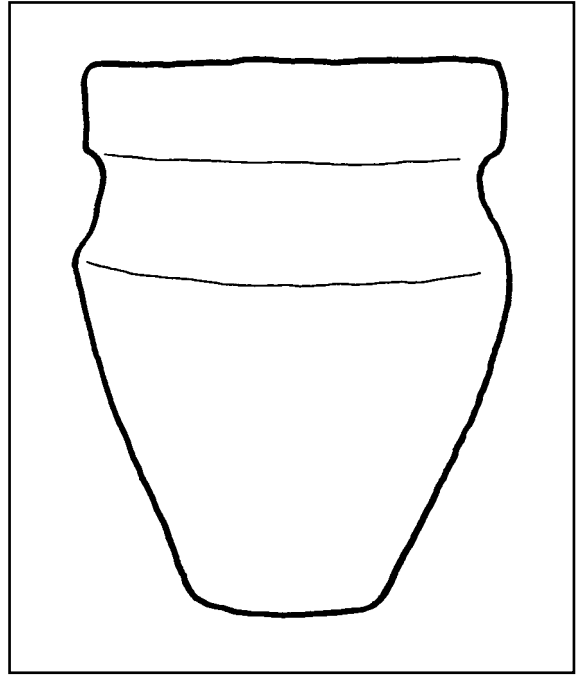

4 Find this Roman pot.
Finish the picture.

Tick how it was made:

- 1) in a mould
- 2) by hand
- 3) on a wheel

What was it used for?

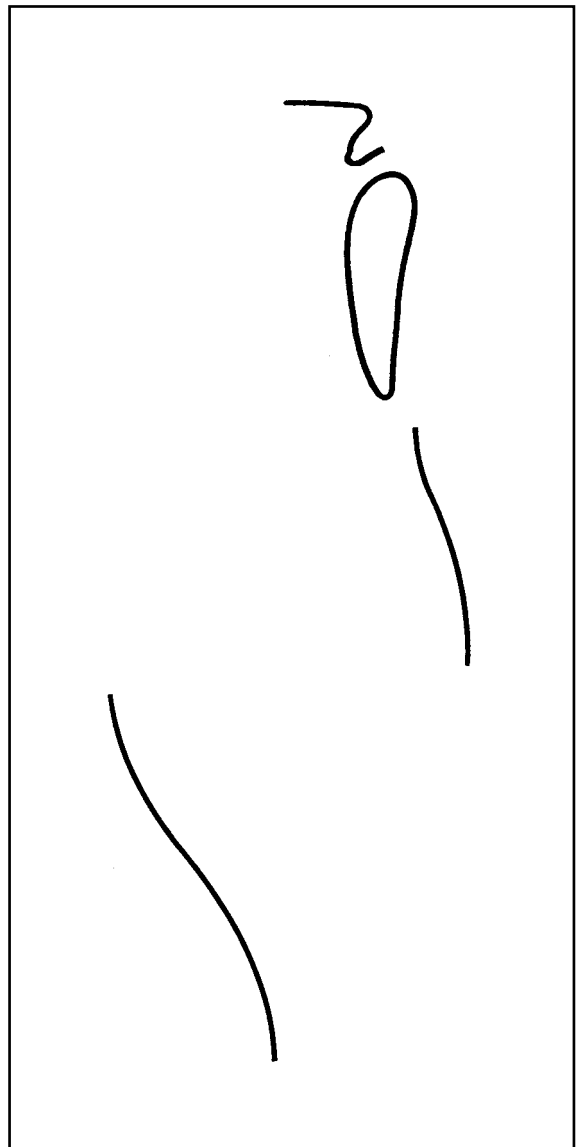

ACTIVITY 2

ROMAN INVASION

- 1** Finish this picture of the Celt and Roman fighting.
Label three differences between the two figures.

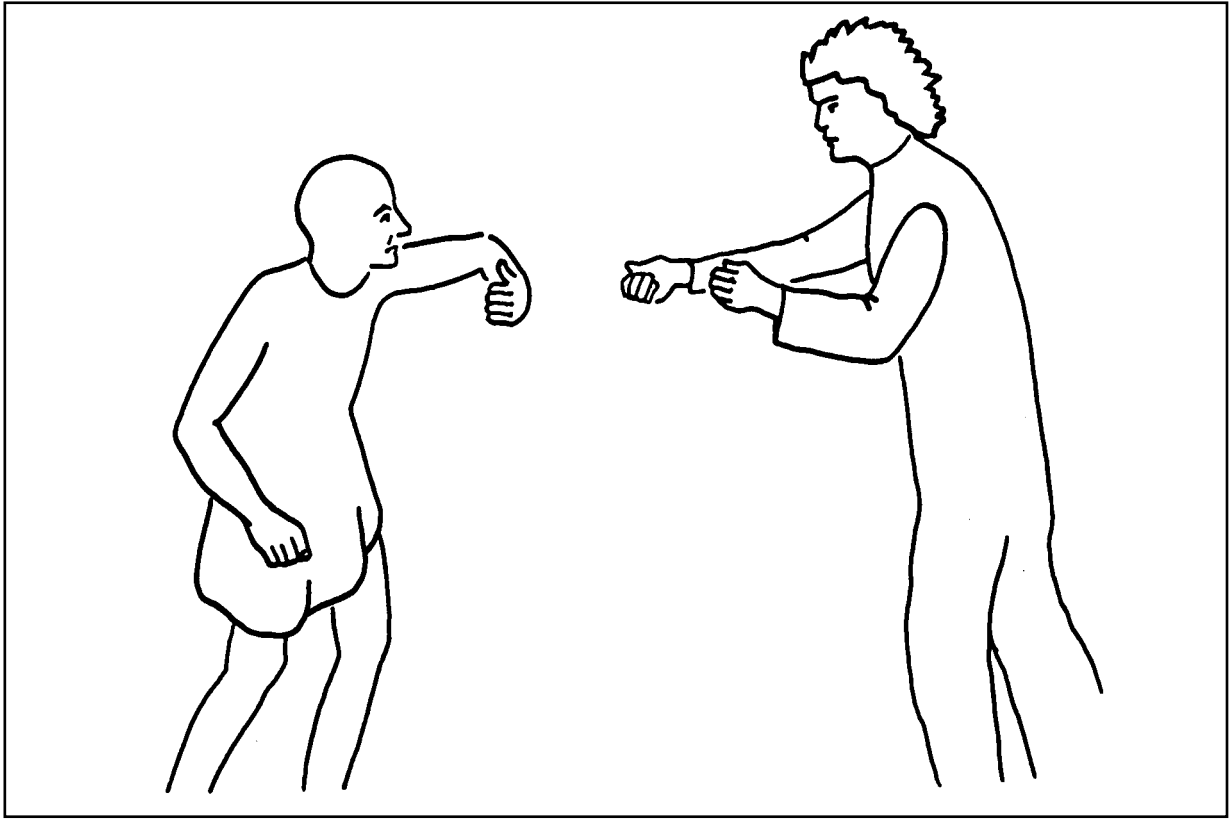

- 2** Find the case with the bronze head of Claudius.

Draw something that was made to celebrate the Roman victories in Britain.



ACTIVITY 2: Roman Invasion

3

Look for the case of soldiers' armour.

Find the dagger and draw it in this box.

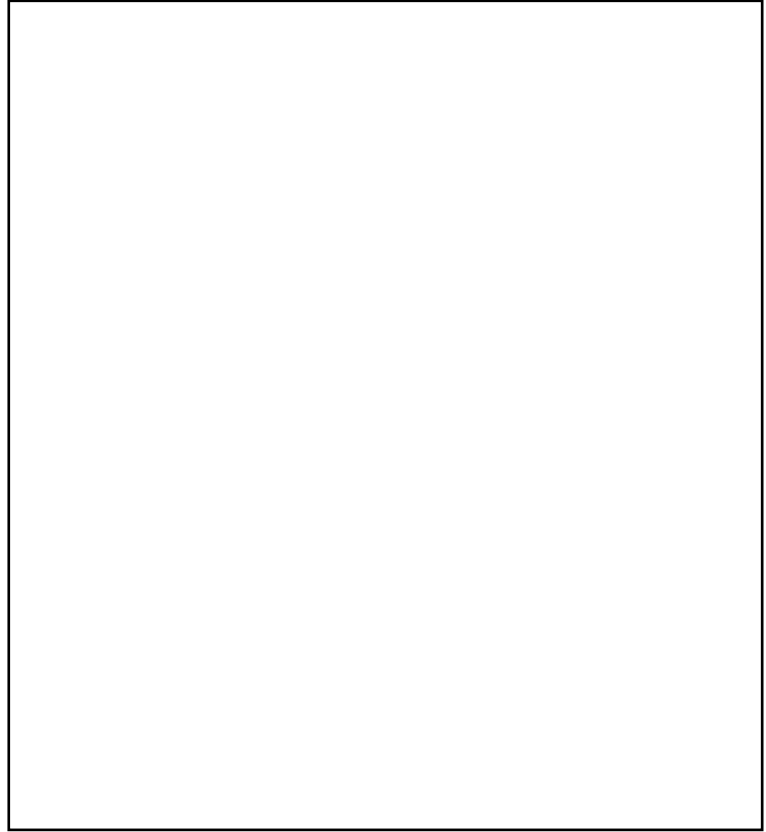

4

Find this tombstone of a Centurion (past the Revenge video).

Label the dagger on the drawing.
Draw in the missing vinestick.
Only centurions were allowed to carry vinesticks which would have been used to beat soldiers who had disobeyed orders.

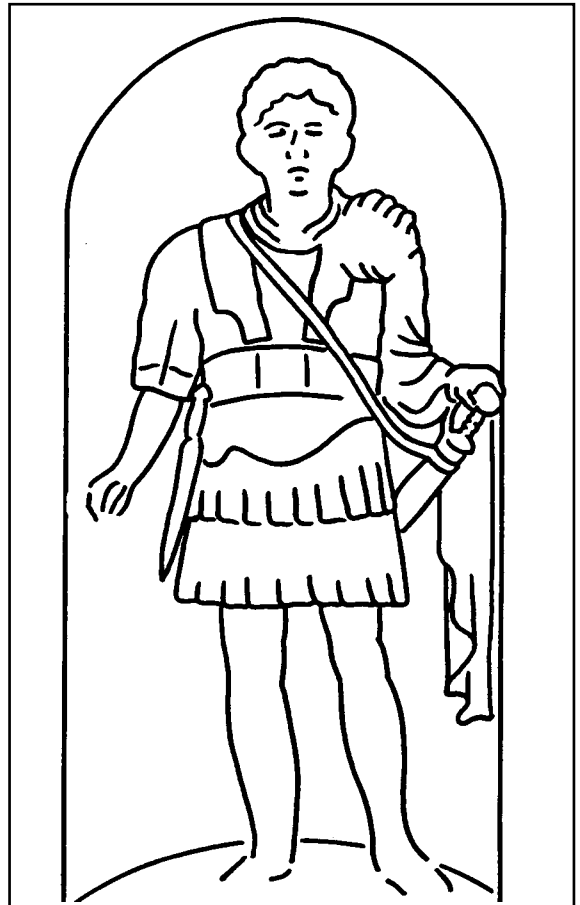

ACTIVITY 3

ROMAN HOMES

BUILDING MATERIALS

- 1** Find a box tile and an antefix and draw them in the spaces below:
Clue: Box tile – look for a hollow clay rectangle
Antefix – look for a clay semi-circle with a face on it.

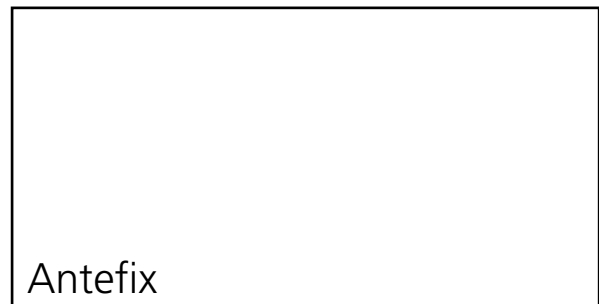
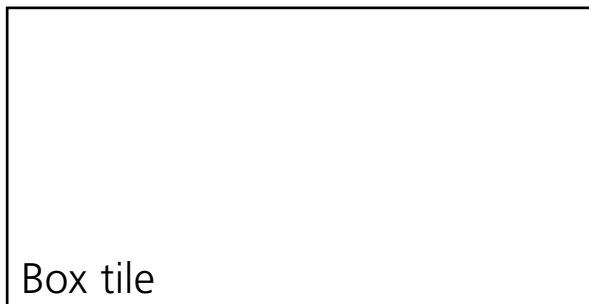

Choose the correct use for these two objects

A box tile was used:

- To cover Roman roofs
- To channel hot air up through the walls in Roman houses
- To make Roman mosaics

A antefix was used:

- To make mosaics
- To decorate Roman doors
- To cover the ends of roofing tiles in a decorative way

- 2** Find the box tiles in this reconstruction and label them.

Fill in the other labels.

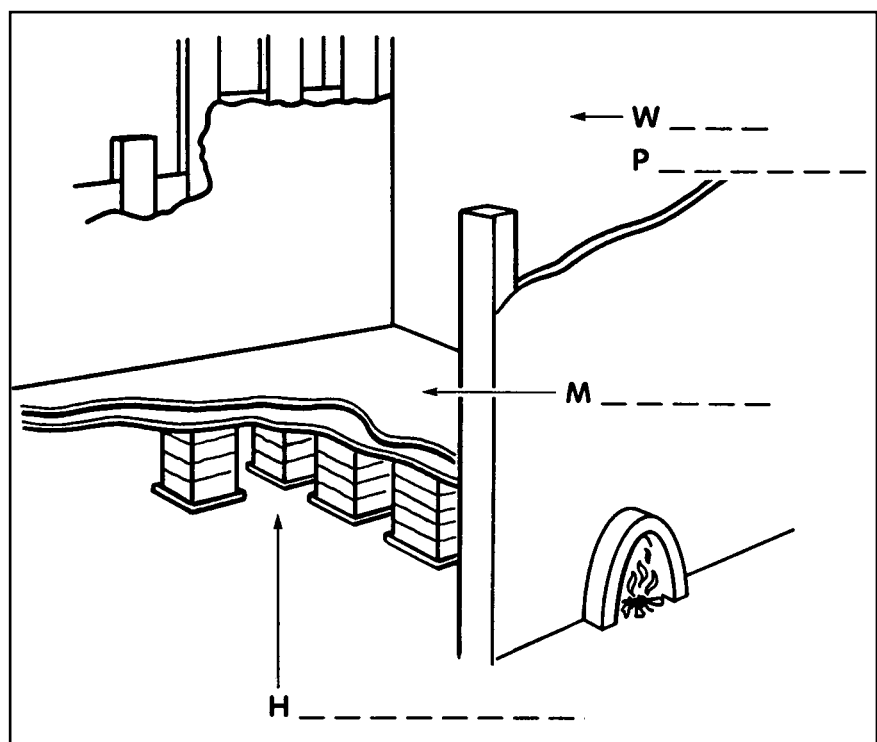

ACTIVITY 3: Roman Homes

3

How is a Roman kitchen different from a kitchen today?

Cross out the objects it doesn't have.

What food can you see in the Roman kitchen?

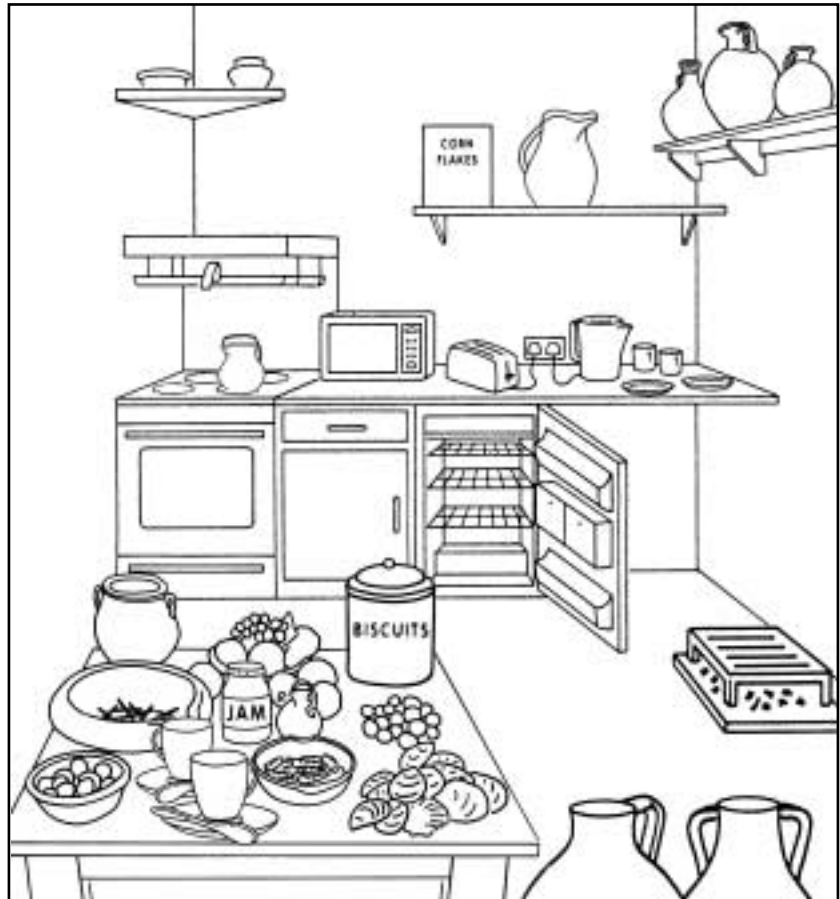

4

Here are "touch" descriptions of the two pots in the 'Feely Box'. Which is which?

Close your eyes and use your sense of touch to identify the two pots.

A. _____

It is heavy and has thick sides. It is rough inside, possibly used for grinding. It was probably used in the kitchen.

B. _____

It is smooth and has thin, even sides. It has an uneven surface on the outside. It was probably used for dinner parties.

ACTIVITY 4

ROMAN LIFESTYLE

- 1** Romans hunted animals as a sport.
How do we know?
Here is a clue.
Find this pot and finish the drawings on it.

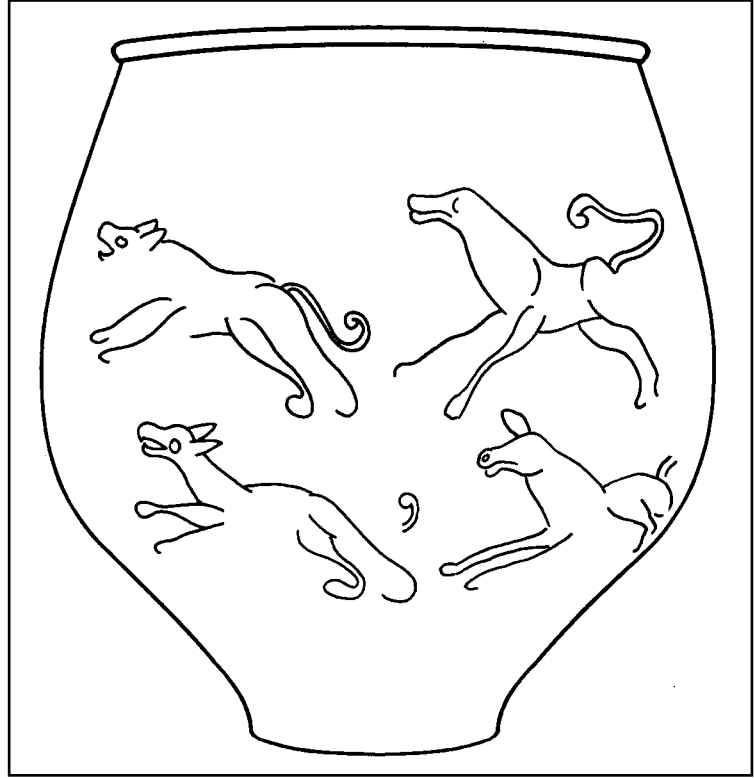

- 2** What did Romans take to the bath house?
Find these two objects and finish the drawings and labels.

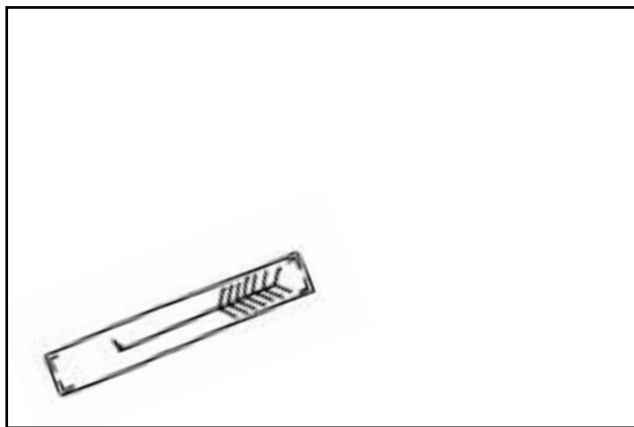

A S_____ was used to
scrape off dirt and sweat.

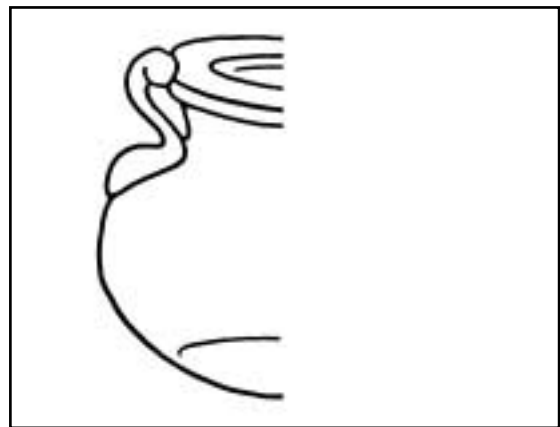

This object contained perfumed
oil to rub into your skin. it is
called an O____ F_____.

ACTIVITY 4: Roman Lifestyle

3

ROMAN MATERIALS

Find objects made out of the materials listed below. Draw and label them in the correct boxes.

Pottery

Metal

Glass

Animal bone

ACTIVITY 5

ROMAN BELIEFS

1 Many gods and goddesses were associated with different animals. Can you find this animal and which god it was linked to.

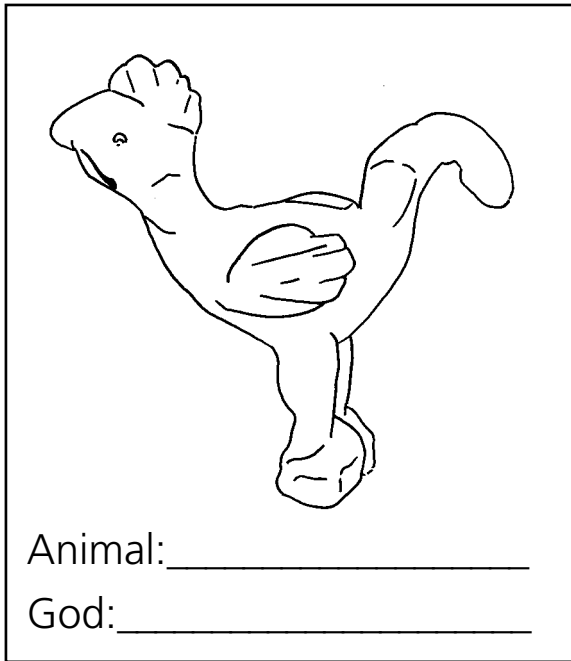

Find one other animal which was associated with a god and draw it in this box.

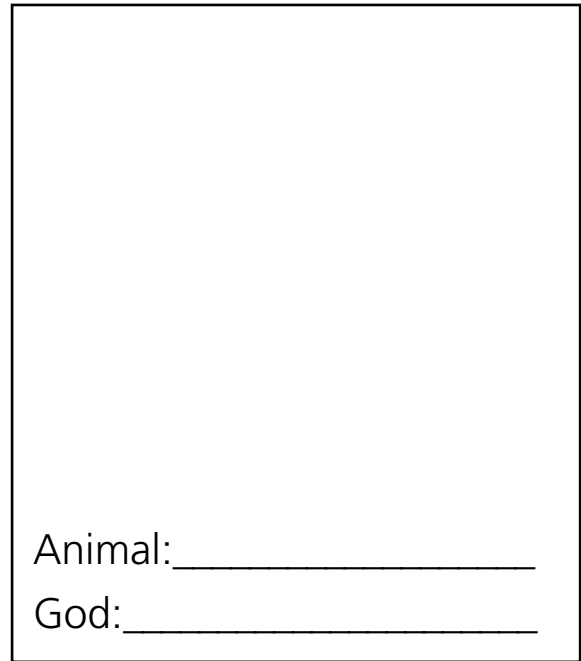

2 This was a plaque placed in a temple by a local man asking the god Mars Medocius to bring him luck.

Make up your own plaque.

Choose a god or goddess to dedicate it to.

Decide what you want to ask.

Write a wish to the god or goddess in your shrine.

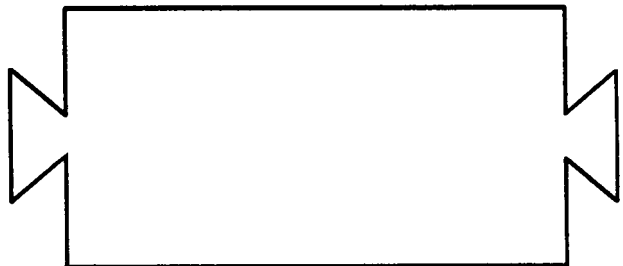
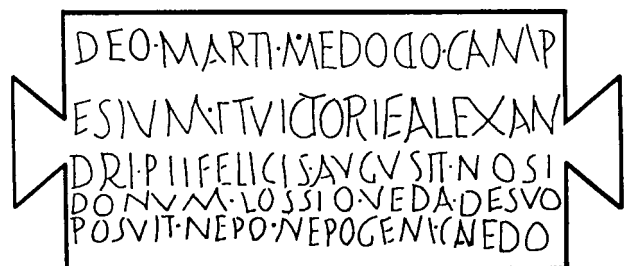

ACTIVITY 5: Roman Beliefs

3 Write 3 things that archaeologists can find out by looking at the skeletons and objects in the graves.

1. _____
2. _____
3. _____

People were often buried with objects that were special to them. Draw an object found in a grave.

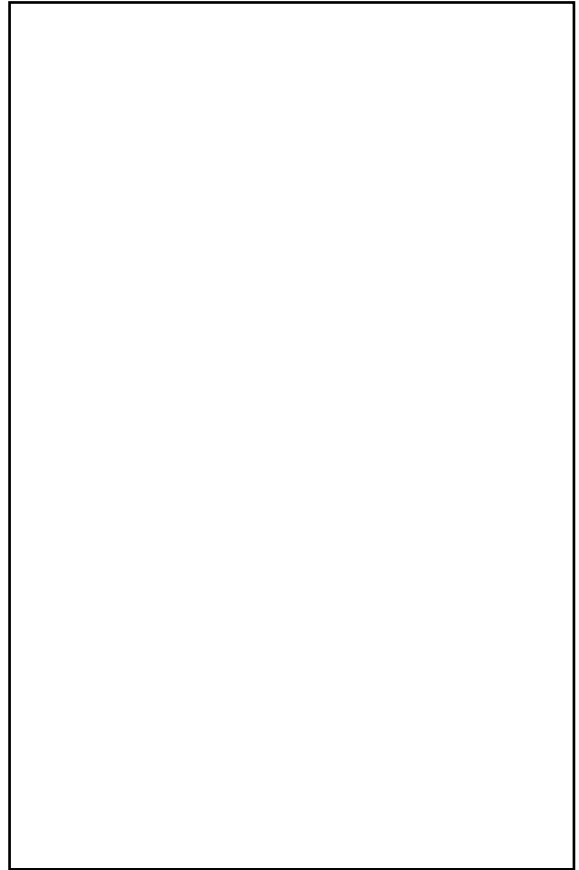

4 Find the lead coffin with this design. Draw in the missing parts of the pattern.

Why did the Romans choose this decoration?

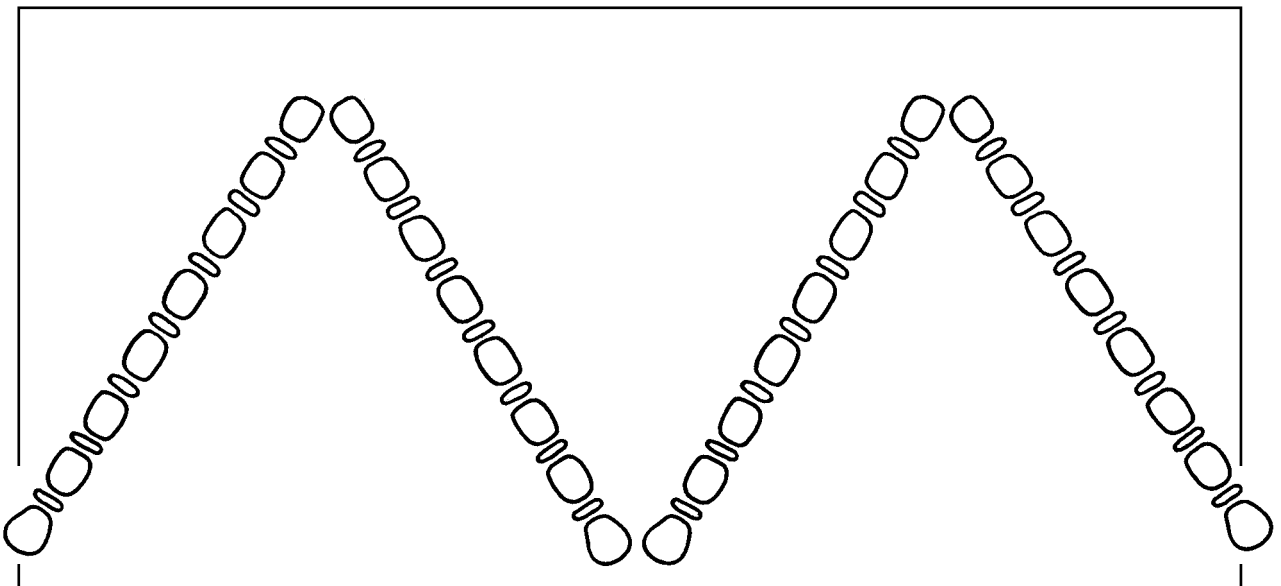

ACTIVITY SHEET

Answers

Activity One – The Evidence

- 1 It is not the same pattern all over. The section that is different is in the top left corner.
- 2 Objects that will survive: spanner, glass bottle, pottery plate.
- 3 The pot was made by hand.
- 4 The Roman pot was made in two parts on a wheel. Its handles would have been made in a mould.

Activity Two – Roman Invasion

- 2 Look for a coin with a picture of the triumphal arch in Rome.
All other questions involve drawing

Activity Three – Roman Homes

- 1
 - A box tile was used to channel hot air up through the walls.
 - An antefix was used to decorate the ends of roofing tiles in a decorative way.
- 2 Correct labels: wall plaster mosaic hypocaust
- 3 Food in the Roman kitchen that is still eaten today: fruit, nuts, oysters, carrots, duck, quails' eggs.
- 4
 - a. Mortarium
 - b. Samian Bowl

ACTIVITY SHEET Answers

Activity Four – Roman Lifestyle

- 1 Representation on pottery is one way we have found that Romans hunted. We have also found hunting weapons and animal skeletons.
- 2 Oil Flask – perfumed oil was rubbed into their skins.
Strigil – to scrape off their dirt and sweat.
(Strigils and oil flasks can be found in the 'Healthy Living' case opposite 'Religious beliefs').
- 3 Drawing question.

Activity Five – Roman beliefs

- 1 The animal is a cockerel. It is associated with Mercury.
Other possible animals: lioness, tortoise, ram.
- 2 Drawing question.
- 3 From the skeletons, archaeologists can find out about gender, general build, illnesses and injuries of the people buried.
From the objects, archaeologists can find out about the religious beliefs, materials and technology employed at that time, wealth of buried people.
- 4 The missing parts of the pattern are scallop shells. The shells represented the journey of the soul across the sea to the Blessed Isles (paradise).

ACTIVITY SHEET

(FIRST CAPITAL AREA)

Find what the Romans used to light their houses.

An O _____ L _____

Finish the picture below.

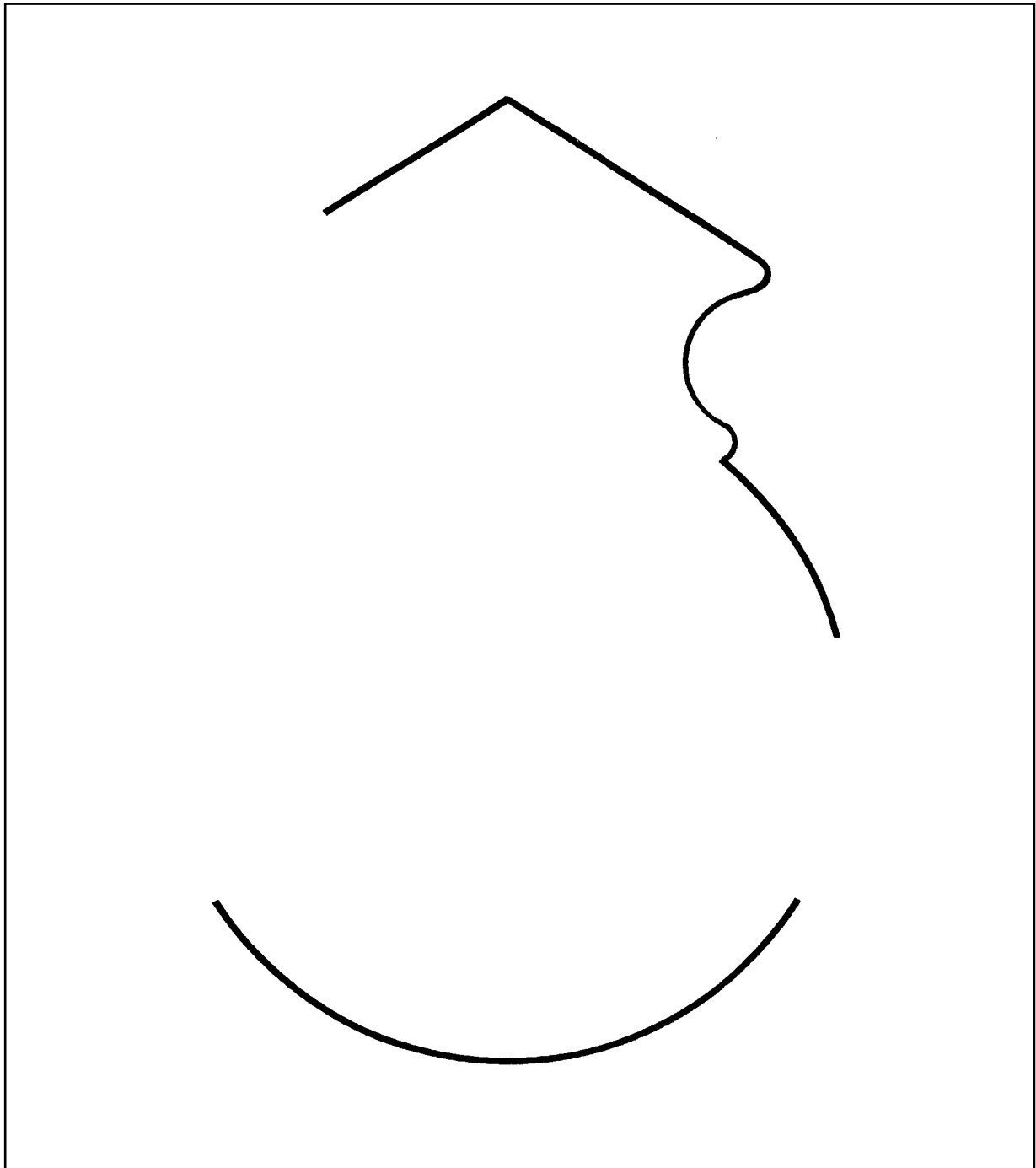

ACTIVITY SHEET

(ROMAN TRADE AREA)

The Romans had many ways of decorating a pot.

Choose the most decorated pot you can find.

Draw the decoration onto the pot below

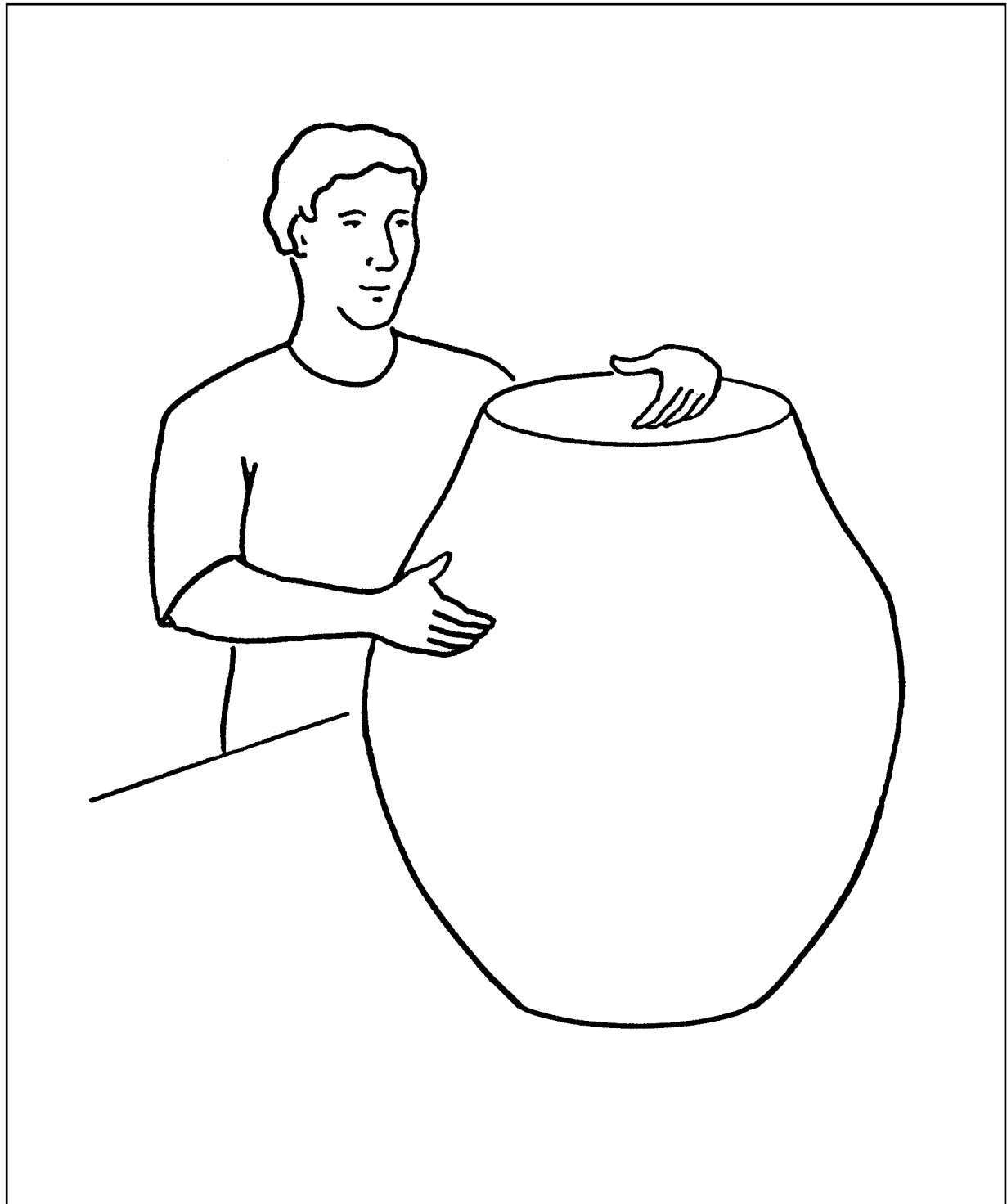

Helpers' Guidelines

Thank you for volunteering to help with the school visit. We hope this sheet will give you support for the day and ideas for looking after your group.

You can help the children by:

- reading difficult text panels to them
- showing them where to find things
- encouraging them to look at objects and have a go at hands-on activities
- sharing their activity sheets - don't worry if they do not finish these sheets or you cannot find some of the objects relating to the questions. Teachers always tell us that it is more important that the children have spent time looking at the displays rather than worrying about finishing their activity sheets.

You can help us by:

- keeping your small group together
- keeping noise levels down
- making sure they are not blocking corridors

Why is Colchester Castle Museum important?

The castle was built in about 1076. It is the largest Norman keep ever built. It was built on the ruins of the Roman temple of Claudius, using the foundations of the temple as its base. The story tour takes you down into the Roman vaults underneath the Norman castle. We do not have dungeons underneath the castle as many people believe, although we do have prisons on the ground floor.

The museum displays tell the early history of the Colchester region from Prehistoric times. They show evidence of Celtic life here 2000 years ago. Colchester (Camulodunum) was an important Celtic settlement in the south east, which was why the Romans made it the first capital of Britannia after the invasion in AD43.

Boudica destroyed the town in AD60, but it was rebuilt after the first defeat. Colchester remained an important Romano-British town until around AD400. It then declined with the coming of the Saxons, but was thriving again by the time of the Norman Conquest in 1066.

Look out for these features of the Castle:

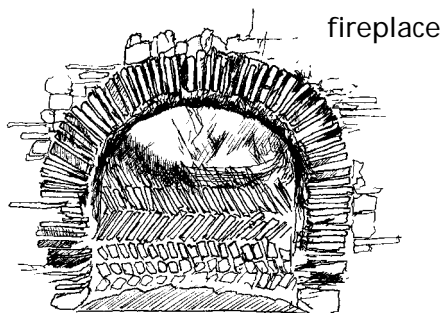

fireplace

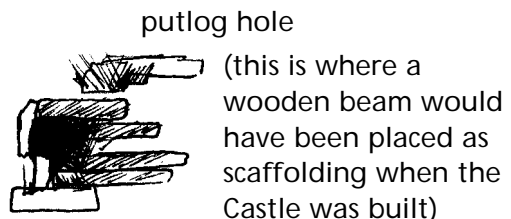

putlog hole

guarderobe (toilet)

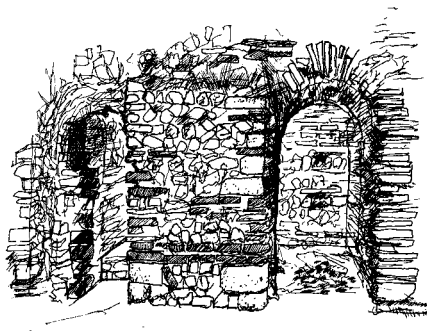

You may also find the following questions useful when encouraging children to look at the displays.

1. Evidence

As you go round the Museum, what types of evidence can you find that tells us about the past? Choose two objects from the Museum and explain what information you learnt about the Romans from it.

e.g. skeleton – this tells us what people's bodies were like.

2. Roman technology

As you go round the Museum, find out what materials the Romans used. Look out for: pottery, bone, glass, clay, metal. Draw and label an object made from each of these. Can you find any Roman objects made from wood or cloth?

3. What was the life style of the Celts like?

Investigate the ground floor area around the Roundhouse for clues about their life. Choose objects or pictures from the displays that show you what they looked like, what they did for a living, what they lived in and how they fought.

4. What was life like for the Celts under Roman rule?

Hunt for skulls of Celts beheaded by the Romans! These can be found upstairs near the Revolt audio visual. Can you find any other objects near these skulls that show us what life was like for the Celts?

5. Boudican revolt

Look for a display upstairs near the two tombstones. Find objects that tell us what happened in the Boudican revolt. What do you think the revolt was like?

6. Roman homes

Look in the upstairs galleries near to the 'Trying on Toga' area. Imagine you are a rich Roman. Choose items from the displays that you would have in your villa.

Think about:

- how you would heat your house
- what decoration you would like
- what food you would eat
- how you will store your food

7. Roman beliefs

Look for coffins and skeletons upstairs! Many people were buried with their belongings. Can you find examples of what was buried with them? Why do you think these objects were chosen?

8. Roman entertainment

Can you find anything in the upstairs galleries that shows what the Romans did in their home or elsewhere to entertain themselves?

Which would you have enjoyed doing?

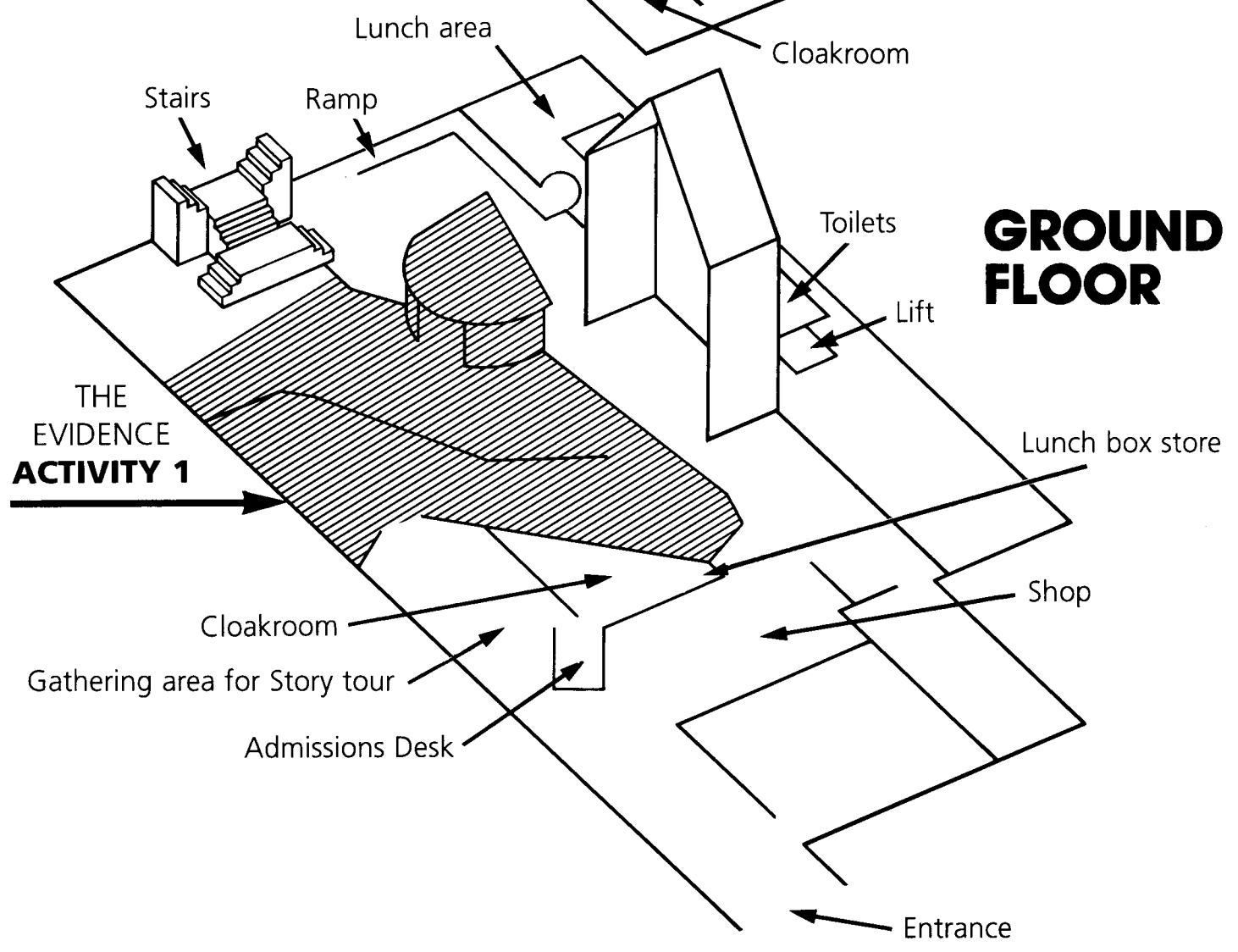
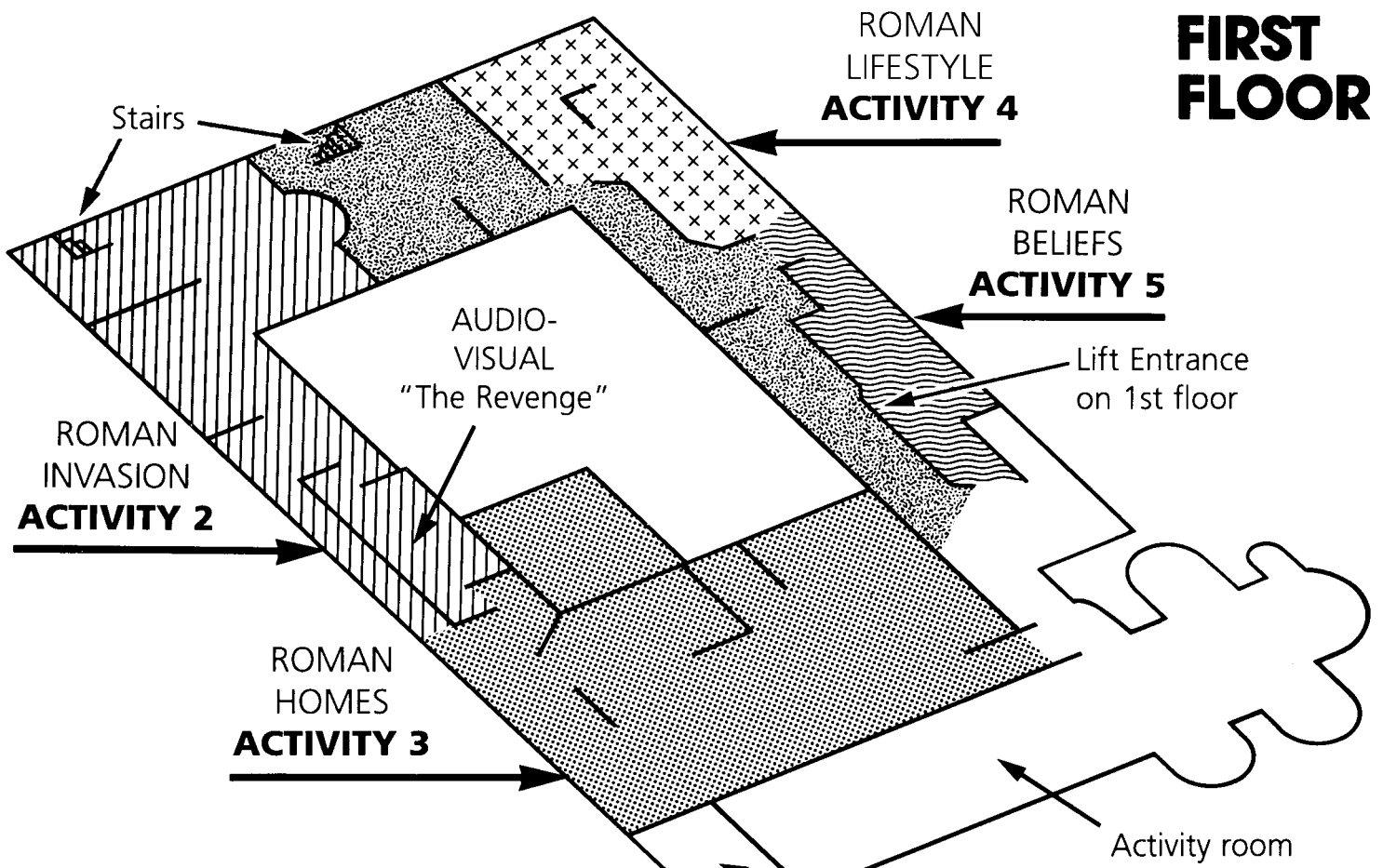

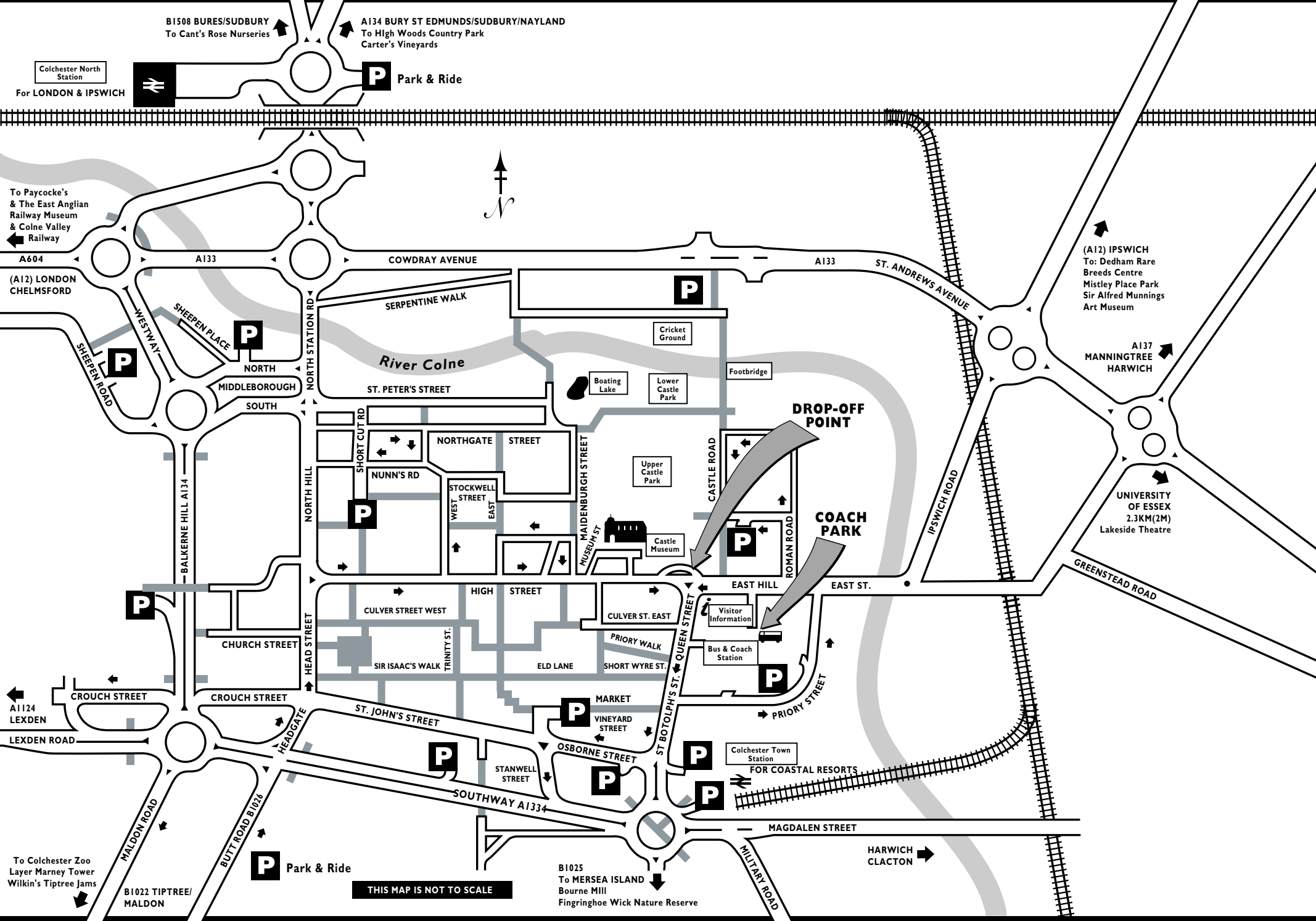

B1508 BURES/SUDBURY
To Cant's Rose Nurseries

A134 BURY ST EDMUNDS/SUDBURY/NAYLAND
To High Woods Country Park
Carter's Vineyards

Colchester North Station
For LONDON & IPSWICH

P Park & Ride

To Paycocke's
& The East Anglian
Railway Museum
& Colne Valley
Railway

(A12) LONDON
CHELMSFORD

(A12) IPSWICH
To: Dedham Rare
Breeds Centre
Mistley Place Park
Sir Alfred Munnings
Art Museum

A137
MANNINGTREE
HARWICH

UNIVERSITY
OF ESSEX
2.3KM(2M)
Lakeside Theatre

To Colchester Zoo
Layer Marney Tower
Wilkin's Tiptree Jams

B1022 TIPTREE/
MALDON

P Park & Ride

THIS MAP IS NOT TO SCALE

B1025
To MERSEA ISLAND
Bourne Mill
Fingringhoe Wick Nature Reserve

HARWICH
CLACTON

SCHOOL VISIT EVALUATION FORM

Please let us have your comments on your visit

Name of school

Name of teacher

Age of children

Date of visit

Type of visit : A B C

Comments on tour (ie length, content, appropriateness, other suggestions)

Comments on Museum galleries

Comments on Activity Sessions (ie organisation, length, tasks, learning content, other suggestions)

Overall standard of visit

Excellent

Very Good

Good

Average

Poor

Other comments

Please return to:

Education Officer

Colchester Museums

Museum Resource Centre

14 Ryegate Road, Colchester, CO1 1YG